



---

---

# KERN MRS120-3

Version 1.0 01/2004

## Operating Instructions

## Moisture Analyzer

---

---

### Contents

<b>1.Introduction</b>	<b>77</b>
1.1 Useful tips on the Operating Instructions	77
1.2 Declaration of conformity	79
<b>2 Safety</b>	<b>80</b>
2.1 Representations and symbols	80
2.2 Safety instructions	80
<b>3 Set up</b>	<b>82</b>
3.1 Unpacking	82
3.2 Transport, storage	83
3.2.1 Transport and shipping	83
3.2.2 Storage	83
3.3 Inspection and assembly	84
3.4 Choosing a suitable location	85
3.5 Connecting it to the mains	86
3.6 Safety measures	87
3.7 Levelling	87
3.8 Weight calibration	88
3.9 First measurement	89
<b>4 Operation</b>	<b>93</b>
4.1 Panel Sheet	93
4.2 Menu control operation principle	94
4.3 Setting and saving the configuration	96
4.4 Instrument configuration	96
4.4.1 Activating the configuration menu	97
4.4.2 Language function	97
4.4.3 Configuring the report printout	98
4.4.4 Configuring the application menu	100
4.4.5 Balance calibration	100
4.4.6 Temperature calibration	100
4.4.7 Interface functions	101
4.4.8 Date and time	101
4.4.9 Password protection	102
4.4.10 Anti-theft encoding	104
4.4.11 Key tone	105
4.5 Application menu operation	106
4.5.1 Activating the application menu	107
4.5.2 Methods	107
4.5.2.1 Saving a method	108
4.5.2.2 Loading a method	109

4.5.2.3	Deleting a method .....	109
4.5.2.4	Setting method name .....	<b>110</b>
4.5.3	Starting weight .....	110
4.5.4	Units .....	110
4.5.5	Print rate.....	112
4.5.6	Standby temperature.....	112
4.5.7	Autostart.....	112
4.6	Special operating keys.....	113
4.6.1	The tare key .....	113
4.6.2	The print key .....	114
4.6.3	The change key.....	117
4.6.4	The start/stop key.....	117
<b>5</b>	<b>Determining moisture levels .....</b>	<b>118</b>
5.1	Fundamental principles.....	118
5.1.1	Adjusting to the existing measuring process .....	119
5.2	Sample preparation .....	119
5.2.1	Preventing samples being encrusted .....	120
5.3	Setting drying parameters.....	121
5.3.1	Heating program .....	121
5.3.2	Temperature.....	123
5.3.3	Timer stop .....	123
5.3.4	Switch-off criteria.....	124
5.4	Application table (recommendations).....	125
<b>6</b>	<b>Data transfer .....</b>	<b>127</b>
6.1	Connection scheme .....	128
6.2	Remote control commands.....	129
6.2.1	Examples of the remote control of the instr. ....	130
<b>7</b>	<b>Service .....</b>	<b>131</b>
7.1	Maintenance and servicing .....	131
7.2	Replacing the mains fuse.....	132
7.3	Calibration.....	133
7.3.1	Calibrating the balance.....	133
7.3.2	Calibrating the temperature.....	135
7.4	Software update via Internet .....	137
7.5	Error messages .....	137
7.4.1	Notes on correcting faults.....	137
<b>8</b>	<b>Overview .....</b>	<b>139</b>
8.1	Technical data .....	139
8.2	Configuration menu tree .....	141
8.2.1	Application menu tree.....	143
8.2.2	Key menus .....	145
8.2.3	Setting drying parameters .....	146
8.2.4	Setting and saving the configuration .....	146

# 1. Introduction

The MRS 120-3 moisture analyzer is simple and functional to operate. It is used as a quick and reliable means of determining the moisture content in powders and liquids by the thermogravimetric principle.

The key features of the MRS 120-3:

- high-end balance technology built to the highest international standard
- optimum resolution
- easy-to-read vacuum fluorescent display
- large viewing window for perfect sample monitoring
- a memory for 5 methods, with all the drying settings
- automatic detection that the measurement has ended by means of ADAPTSTOP
- password protection to prevent unauthorized changes to the instrument configuration and drying parameters
- anti-theft code
- printout in line with GLP guidelines (Good Laboratory Practice)
- software update via the Internet

## 1.1 *Useful tips on the Operating Instructions*

Take the time to read these Operating Instructions from start to finish so that you can make full use of the many benefits and possibilities of the MRS 120-3 in your day-to-day work.

These Operating Instructions contain guidance in the form of pictographs and keypad diagrams, which should help you in finding the required information:

- Key names are presented inside quotation marks and are highlighted in bold font: «**ON/OFF**» or «».
- In order to aid clarity in the explanation of the operating steps, the display for each step is shown graphically on the left alongside the list of operating steps:

## Display shows

Sprache Deutsch

or

Langue française

or

language english

## List of operating steps

- If you press the «  » key repeatedly, “SPRACHE DEUTSCH”, “LANGUAGE ENGLISH” or “LANGUE FRANCAISE” appears in the display.

– See **section 2 "Safety"** for the symbols to indicate risks and tips.

## 1.2 Declaration of conformity



**KERN & Sohn GmbH**

Ziegelei 1

D – 72336 Balingen

E-Mail: [info@kern-sohn.com](mailto:info@kern-sohn.com)

Tel: 0049-[0]7433- 9933-0

Fax: 0049-[0]7433-9933-149

Internet: [www.kern-sohn.com](http://www.kern-sohn.com)

### Declaration of conformity

**Declaration of conformity for apparatus with CE mark**  
**Konformitätserklärung für Geräte mit CE-Zeichen**  
**Déclaration de conformité pour appareils portant la marque CE**  
**Declaración de conformidad para aparatos con disitintivo CE**  
**Dichiarazione di coformità per apparecchi contrassegnati con la marcatura CE**

- English** We hereby declare that the product to which this declaration refers conforms with the following standards.
- Deutsch** Wir erklären hiermit, daß das Produkt, auf das sich diese Erklärung bezieht, mit den nachstehenden Normen übereinstimmt.
- Français** Nous déclarons avec cela responsabilité que le produit, auquel se rapporte la présente déclaration, est conforme aux normes citées ci-après.
- Español** Manifestamos en la presente que el producto al que se refiere esta declaración est´a de acuerdo con las normas siguientes
- Italiano** Dichiariamo con ciò che il prodotto al quale la presente dichiarazione si riferisce è conforme alle norme di seguito citate.

**Moisture Balance: KERN MRS120-3**

Mark applied	EU Directive	Standards
	73/23EEC Low voltage	EN 61010
	89/336EEC EMC	EN 61326

Date: 02.03.2004

Signature: 

Gottl. KERN & Sohn GmbH

Management

Gottl. KERN & Sohn GmbH, Ziegelei 1, D-72336 Balingen, Tel. +49-[0]7433/9933-0, Fax +49-[0]7433/9933-149

## 2 Safety

### 2.1 Representations and symbols

Important safety-related instructions are highlighted visually at the description of what to do:

<b>DANGER</b>
<b>Warning of a possible danger which may lead to death or to serious injury.</b>

<b>CAUTION</b>
<b>Warning of a possible danger which may lead to minor injury or damage.</b>

<b>NOTE</b>
Tips and important rules on how to use the MRS 120-3 moisture analyzer correctly.

### 2.2 Safety instructions

- When using the instrument in surroundings with increased safety requirements, pay careful attention to the appropriate regulations.
- Only use an extension cord with a protective earth conductor.
- If the mains cord is damaged, disconnect the instrument from the electrical supply immediately and replace the mains cord.
- If there is any reason to believe that it is no longer possible to operate the MRS 120-3 safely, unplug the instrument immediately from the electrical supply and secure it so that it cannot be operated inadvertently.
- When carrying out maintenance work, it is essential to heed the tips in (cap. 7.1 Maintenance and servicing).
- The Operating Instructions must be read by everyone who has to operate the instrument and must be kept handy on-site at all times.

## **DANGER**

Do not place any flammable materials on, under or beside the instrument.

Leave enough clear space around the instrument to prevent a build-up of heat.

The MRS 120-3 may not be used to analyze explosive, highly flammable samples.

Do not operate the MRS 120-3 moisture analyzer in areas where there is any risk of explosion.

Sample materials which release toxic substances must be dried in a fume hood. Take care not to inhale any harmful vapors.

Ensure that no liquid seeps inside the instrument or into the connection ports on the back of the instrument.

If you spill any liquid onto the instrument, unplug it from the electrical supply immediately.

Do not operate the moisture analyzer again until you have had it checked by a KERN service engineer.

## **CAUTION**

Some of the parts, like the heating element and the viewing window, may become considerably hotter while it is in operation. Only touch the instrument using the handles provided.

Take care when you remove the sample. The actual sample, the heating unit and sample pans used may still be very hot.

The MRS 120-3 should generally be used for drying substances containing water. Sample materials which give off aggressive vapors (like acids) may cause corrosion problems to develop on parts of the instrument.

If any damage or injury occurs, liability and responsibility rest with the user.

## 3 Set up

### 3.1 Unpacking

The MRS 120-3 moisture analyzer comes in environmentally-friendly packaging, specifically developed for this precision instrument, which provides optimum protection for the instrument during transportation.

NOTE
Retain the original packaging in order to avoid the MRS 120-3 moisture analyzer becoming damaged in transit when it is shipped or transported and to store the MRS 120-3 under optimum conditions if it is out of operation for an extended period.

Follow instructions carefully when you unpack the MRS 120-3 moisture analyzer in order to avoid damaging it:

- Unpack the instrument carefully and gently. This is a precision instrument.
- When temperatures outside are very low, the balance should first be stored for a few hours in the unopened transport package in a dry room at normal room temperature, so that no condensation settles on the balance when it is unpacked.
- Check the moisture analyzer for any external visible signs of damage immediately after you unpack it. If you find that it has been damaged in transit, notify your KERN service agent immediately.
- If the MRS 120-3 moisture analyzer is not being put into operation immediately after purchase, store it in a dry place with minimal fluctuations in temperature (Cap.3.2.2 “Storage”)
- Read these Operating Instructions carefully before operating the balance, even if you have used KERN equipment before and pay particular attention to the safety instructions (Cap.2 “Safety”).

## **3.2 *Transport, storage***

### **3.2.1 Transport and shipping**

Your MRS 120-3 moisture analyzer is a precision instrument. Treat it with care.

Avoid shaking it or subjecting it to any heavy jolts or vibrations during transport.

Avoid serious temperature fluctuations and getting the instrument damp (condensation) during transport.

NOTE
The MRS 120-3 moisture analyzer should ideally be shipped and transported in its original packaging to avoid damage in transit.

### **3.2.2 Storage**

If you do not intend to use the instrument for a long time, unplug it from the electrical supply, clean it thoroughly and store it in a place that meets the following conditions:

- No serious shaking or vibrations
- No serious fluctuations in temperature
- No direct exposure to sunlight
- No moisture

NOTE
The MRS 120-3 moisture analyzer should ideally be stored in its original packaging because it gives it optimum protection.

### 3.3 Inspection and assembly

The moisture analyzer does not come fully assembled. Once you have unpacked all the parts, check that the delivery is complete and assemble the individual components in the order indicated below.

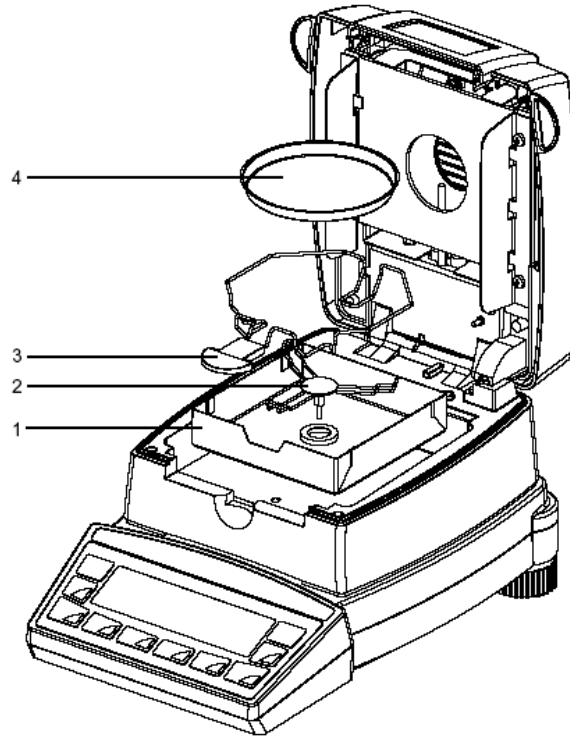

Components delivered	Components delivered
MRS 120-3 moisture analyzer	In-use cover for the display
Mains cord	30 sample pans (4)
Draftshield (1)	Operating Instructions
Pan support (2)	Warranty card
Sample holder (3)	Declaration of conformity

- Assemble the in-use cover for the display
- Open the hood and insert the draftshield (1), making sure that it is placed on flat.
- Insert the pan support (2) and turn it so that it locks securely in place.
- Insert the sample holder (3) as shown.
- You can now place an aluminium pan (4) on the pan support.

#### NOTE

All the parts must be attached together without exerting undue force. Do not apply any force. If you have any problems, the KERN customer service will be happy to help.

### **3.4 Choosing a suitable location**

In order to ensure that the moisture analyzer functions properly, select a location that fulfils the following criteria:

- Permissible ambient temperatures
  - Temperature: 5°C ... 40°C
  - Relative humidity: 25% ... 85%, non-condensing
- Put the instrument on a rigid, firm horizontal base, preferably exposed to no vibrations
- Make sure that the instrument cannot be shaken or knocked over
- Do not expose it to direct sunlight
- Avoid drafts and excessive temperature fluctuations
- Leave enough clear space around the instrument to prevent a build-up of heat.

Do not expose the instrument to high levels of moisture for long periods of time. Avoid letting condensation form on the instrument. If instruments are cold, let them warm up to room temperature (approx. 20°C) before connecting them to the mains. Condensation is practically impossible on instruments which are connected to the mains.

### 3.5 Connecting it to the mains

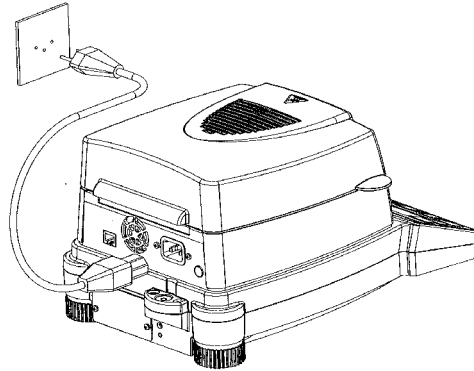

Follow safety instructions when connecting the instrument to the mains:

#### **DANGER**

The instrument may only be operated using the original mains cord supplied.

If the mains cord supplied is not long enough, only use an extension cord fitted with a protective earth conductor.

Plug the mains cord into a socket which has been installed in accordance with regulations and is fitted with a PE terminal.

For technical reasons, the heating unit is designed in the factory to accommodate a voltage of 230 V or 115 V and in accordance with your order. Check that the setting matches the local setting?

### 3.6 Safety measures

The safety class 1 instrument, the MRS 120-3, may only be plugged into a socket which has been installed in accordance with regulations and is fitted with a protective earth terminal. The safety effect may not be undone by using an extension lead without an earth wire. If the voltage is coming from mains supplies without a protective earth terminal, arrange for an electrician to create a comparable level of protection in accordance with valid installation regulations.

### 3.7 Levelling

In order to function properly, the MRS 120-3 moisture analyzer must be precisely horizontal.

The instrument is fitted with a “levelling bubble” and two rotatable feet for level-control, with the aid of which it is possible to compensate for small height differences and/or unevennesses in the surface on which the instrument is standing.

The two screw feet must be adjusted so that the air bubble is precisely in the center of the sight glass of the levelling bubble.

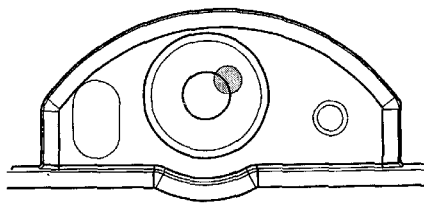

**Incorrect**

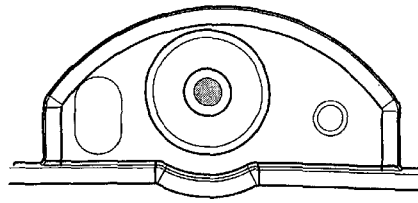

**Correct**

<b>NOTE</b>
The instrument must be carefully relevelled each time it is moved in order to obtain accurate measurements.

### **3.8 Weight calibration**

Since the Earth's gravity is not the same everywhere, each balance must be adjusted to compensate for the gravity at each location, in accordance with the underlying physical weighing principle. This adjustment process, which is known as “calibration”, must be carried out on initial installation and then each time the instrument is moved to another location. However, in order to get exact measurements, the instrument should also be recalibrated periodically.

NOTE
The MRS 120-3 moisture analyzer must be calibrated when it is initially installed and then each time it is moved to another location. If you work in accordance with “Good Laboratory Practice GLP”, observe the prescribed intervals between calibrations (adjustments).

The calibration is set in the configuration menu (see chapter 4.4.5 "Balance calibration")

With the aid of the “Intelligent Calibration Mode” (ICM), the instrument can determine the size of the calibration weight itself, facilitating exact calibration with different size weights (in 10 g increments);(see chapter 7.3.1 "Calibrating the balance")

### 3.9 *First measurement*

Once the MRS 120-3 moisture analyzer is successfully up and running, you can perform an initial measurement to familiarize yourself with the new instrument and to test it for any malfunctions. Switch the instrument on using the «**ON/OFF**» key. The instrument performs a self-diagnostics test to check the main functions. After completion of the start-up process (which takes about ten seconds), “Zero” appears in the display; this means that the instrument is now ready for operation.

During the first measurement, the instrument uses the drying parameters set in the factory.

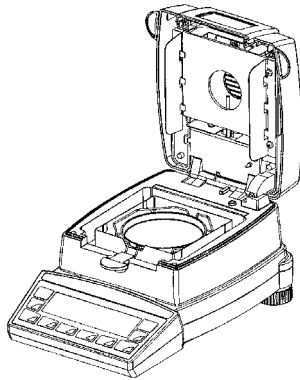

- Open the hood of the instrument
- Place the sample holder with an empty weighing pan onto the weighing pan holder.  
Note: The weighing pan must sit flat on the weighing pan holder. Always work with the sample holder; it allows you to work safely and prevents possible burning ones self.
- Press the « TARE » key.  
The instrument is ready to weigh the sample.

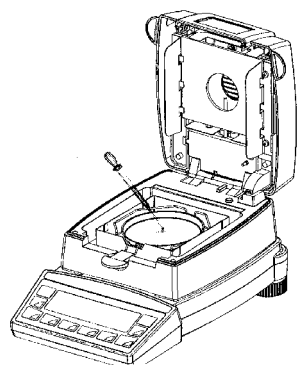

- Pour approx. 1.0 g of water into the weighing pan.

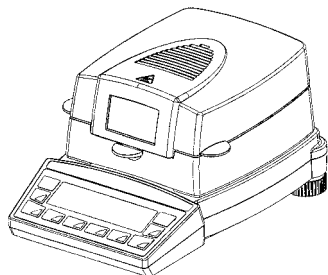

- Close the hood  
The instrument is prepared for the first measurement.



- Start the measurement by pressing the «**START/STOP**» key.  
The heating element heats up to 105°C, and the fan starts to cool.

+	100.00	%
STd--	°C	0.1MIN

- The dryer display is divided into
- the measurement display and the info line

+	93.27	%
STD	105°C	2.3MIN

- The result appears in the measurement display in the unit of measurement set.
- The info line displays the heating mode used (standard), the current temperature (105°C) and the current duration of the measurement (2.3 min.).  
If the temperature is under 40°C, three dashes are displayed: "--- °C".
- Once the drying has ended, an audio signal sounds, and the heating is switched off.

The fan keeps running until the temperature in the sample room drops below 40°C.

+	XX.xx	%
DURATION XX.X MIN		

- The measurement display shows the result in the unit of measurement set. The measurement result is displayed in the other units of measurement by pressing the «F» key.
- The info line shows how long the measurement takes.

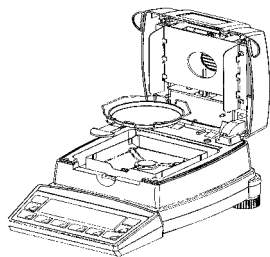

- Open the hood
- Carefully remove the weighing pan, only gripping the sample holder by the handle.  
Caution! All the parts of the sample chamber are hot. Allow the weighing pan and holder to cool down before doing anything else with them.
- Insert a new weighing pan into the instrument.
- Press the «**TARE**» key; the instrument is ready for you to perform a new measurement.

## CAUTION

The weighing pan and holder are hot!

## 4 Operation

The MRS 120-3 moisture analyzer has two main menus: the configuration menu and the application menu.

Instrument-specific parameters and the layout of the report printout are defined in the **configuration menu**. You can either work with the basic configuration programmed in the factory or define and save a user configuration which is adapted to suit your specific needs.

Dryer-specific parameters can be set in the **application menu**. The weighing help is also activated and defined in this menu.

### 4.1 Panel Sheet



## 4.2 Menu control operation principle

The configuration menu and the application menu each have a main path and up to two sub-paths in which the parameters for the different functions of the instrument are defined.



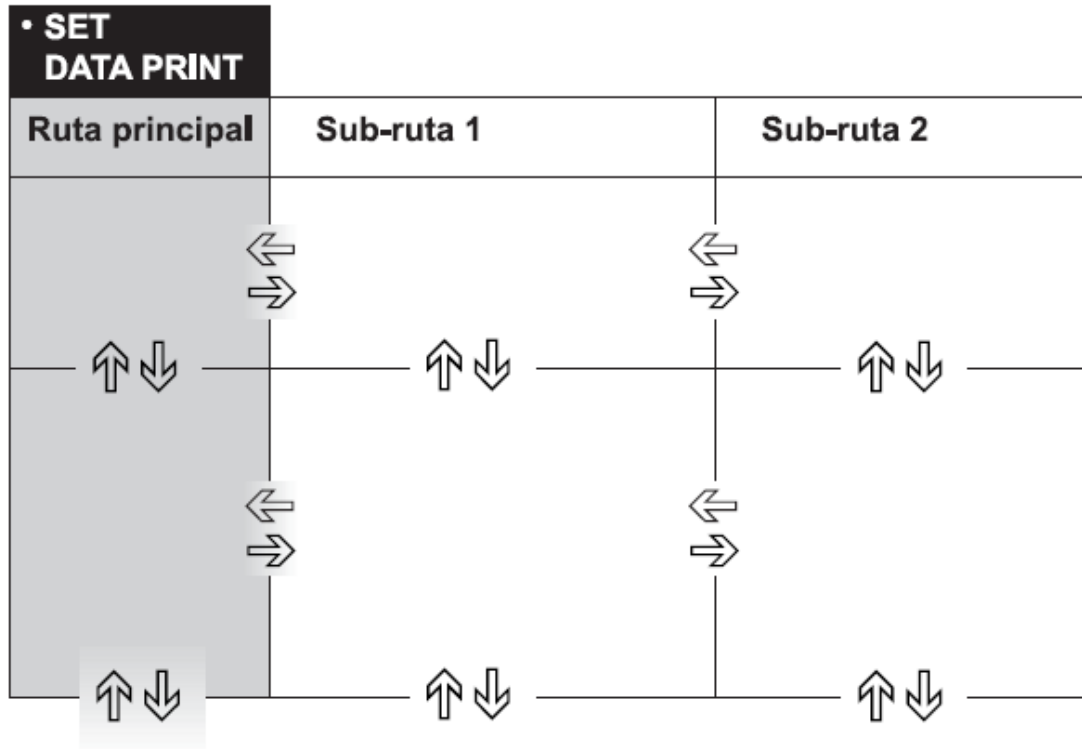





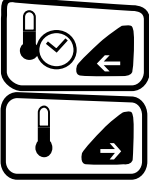

Use the cursor keys «», «», «» and «» to move within the paths.

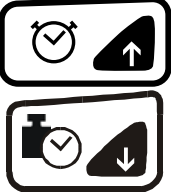

## NOTE

The geometry of the menu tree diagram corresponds to the path configurations of the two main menus.

In **program operation mode**, the **key symbols highlighted in blue** apply on the control panel.

Key(s)	Designation	Function in weighing mode
	 	<ul style="list-style-type: none"> <li>Changes from the main menu path to the sub-paths and vice versa.</li> </ul>
	 	<ul style="list-style-type: none"> <li>Moving up/down within the main path or sub-paths.</li> <li>Changing selected parameters</li> </ul>
		<ul style="list-style-type: none"> <li>Selecting parameters</li> <li>Saving the changed parameters</li> </ul>
	«esc»	<ul style="list-style-type: none"> <li>Cancelling an entry</li> <li>Exiting the menu</li> </ul>
	«ins»	<ul style="list-style-type: none"> <li>Setting a space (in text entries)</li> </ul>
	«clr»	<ul style="list-style-type: none"> <li>Clearing an entry (in text entries)</li> </ul>
	«PRINT»	<ul style="list-style-type: none"> <li>Entering a decimal point (in text entries)</li> </ul>

### 4.3 Setting and saving the configuration

- Press «**ON/OFF**» to switch the instrument on.
- During the start-up process, keep the «**TARE**» and «**MENU**» keys pressed in until the configuration you require appears in the display, then let the keys go:

"FACTORY CONFIG.": Load the factory configuration.

"USER CONFIG.": Load the user configuration.

"STORE CONFIG": Save the current configuration as the user configuration.

### 4.4 Instrument configuration

This section explains the structure of the configuration menu and its functions.

Main path	Definable functions
<b>SET DATA PRINT</b>	<i>Print formats; type of values to print</i>
<b>SET APP. MENU</b>	<i>Defining the application menu</i>
<b>SET BALANCE CAL.</b>	<i>Balance calibration method</i>
<b>TEMP. CAL</b>	<i>Activate the temperature calibration</i>
<b>SET INTERFACE</b>	<i>Baud rate, parity, handshake functions of periphery interface</i>
<b>SET DATE AND TIME</b>	<i>Date and time (standard format or American format p.m. and a.m.)</i>
<b>PASSWORD</b>	<i>Password protection for the menu definitions</i>
<b>THEFTCODE</b>	<i>Activation/deactivation and change to the anti-theft code</i>
<b>KEY TONE</b>	<i>Activation of the keypad sound</i>
<b>CONTRAST</b>	<i>Not described</i>
<b>LANGUAGE</b>	<i>Language (E, D, F)</i>

Representation conventions:

- The settings programmed in the factory are depicted in **bold**.
- In order to aid clarity, the only part of the menu tree shown in each function description is the part which relates to the function in question.

Explanations on the menu functions are depicted in *italics*.

#### 4.4.1 Activating the configuration menu

- Press «**ON/OFF**» to switch the MRS 120-3 on.
- Keep the «**MENU**» key pressed in continuously during the start-up process (which takes about ten seconds) until "SET DATA PRINT" appears in the display.
- You can now change the configuration menu.

#### 4.4.2 Language function



*Selecting a language*

Procedure for changing the language:

SPRACHE DEUTSCH

or





LANGUE FRANÇAISE

or

LANGUAGE **ENGLISH**

LANGUAGE ENGLISH

SPRACHE DEUTSCH

- Activate the configuration menu
- If you press «», the language currently activated is displayed.
- If you press «»
- The language flashes now.
- Keep pressing «» until the language you require appears.
- Press «» to confirm the choice of language.
- Press «**esc**» to exit the menu.

### 4.4.3 Configuring the report printout

The report printout can be configured in the "SET DATA PRINT" menu option. The options marked "ON" are contained in the report and are printed.

The "MODE PC" function allows the measurement printout to be output in a format which the PC can support. This format only affects the print rate printout and is used for the graphical evaluation of the drying process with the aid of a computer program (such as Excel). The individual measurements are output separated by tabs, allowing them to be imported easily into a table.

<b>• SET DATA PRINT</b>		
	SET PRINTFORMAT	DATE AND TIME <b>ON/OFF</b> BALANCE-ID <b>ON/OFF</b> METHOD-ID <b>ON/OFF</b> COUNTER <b>ON/OFF</b> DRYER SETUP <b>ON/OFF</b> PRINT RATE <b>ON/OFF</b> OPERATOR-ID <b>ON/OFF</b>
		PRINT RATE <b>1.0 MIN</b>
		OPERATOR ttt...
	MODE <b>PRINTER</b>	<i>Printout in text format (40 characters)</i>
	MODE PC	<i>Print rate printout in a format supported by the PC. The individual measurements are separated by a tab.</i>

The elements set in "SET PRINTFORMAT" are printed out.

- The interval at which interim results are printed is set at "PRINT RATE". The print interval can be set in 0.1 min increments from 0.1 ... 10.0 min.
- An alphanumerical ID can be entered for the operator at "OPERATOR ttt...".

When a peripheral instrument (e.g. a printer) is connected, the instrument interface must be configured in the "SET INTERFACE" submenu.

Example of a report printout with all the available selection options.

***** KERN MRS 120-3 ***** -----	<i>Report title, only output in printer mode.</i>
Date 07.10.2002      Time 11:06:01	<i>Date and time, if this is switched on.</i>
Name            : MRS 120-3 Software        : N50-0040 Serialno        : 3300-1	<i>Balance ID, if this is switched on</i>
Method         : Boost/100C	<i>Method ID, if this is switched on</i>
Number         : 1	<i>Measurement series counter, if this is switched on</i>
Heat mode      : Boost Temperature    : 100 C Stop time      : 10.0 Min Autostop       : 2/20 D/s  Standby temp.  : 40 C	<i>Dryer setup, if this is switched on</i>
Original weight : +  2.186 g	<i>Starting weight is always output</i>
Mode Temp      Time            100-0% ----- B  105 C    1.0 Min    +  86.81 % B  140 C    2.0 Min    +  68.08 % B  140 C    3.0 Min    +  51.97 % 102 C    4.0 Min    +  44.05 % 98 C     5.0 Min    +  37.70 % 100 C    6.0 Min    +  29.84 % 100 C    7.0 Min    +  24.38 % 100 C    8.0 Min    +  22.64 %  END100 C    8.2 Min    +  22.60 %	<i>The measurement is printed in the unit set for drying, provided the print rate function is switched on. The individual values are separated by tabs in the "MODE PC".</i>
100-0%         : +  22.60 % Residual weight : +  0.494 g  Stop            : Autostop Duration        : 8.2 min	<i>Drying results are always output</i>
Operator        : SAMPLE	<i>Operator ID, if this is switched on</i>

## 4.4.4 Configuring the application menu

• SET APP. MENU		
	EDIT METHOD	ON/OFF
	METHOD-ID	ON/OFF
	TARGET WEIGHT	ON/OFF
	UNIT	ON/OFF
	PRINT RATE	ON/OFF
	STANDBY TEMP.	ON/OFF
	AUTOSTART	ON/OFF

The options activated under "SET APP. MENU" are enabled in the application menu and can be changed and set there (see chapter 4.5 "Application menu operation").

## 4.4.5 Balance calibration

• SET BALANCE CAL.		
	MODE	OFF <i>disabled</i>
	MODE	<b>EXTERNAL</b> <i>external</i>
	MODE	EXT.-DEF. <i>external with a freely defined weight (DEF. n.nnn g)</i>
	DEF.	<b>0.0000 g</b> <i>Calibration weight for the EXT. DEF. mode</i>

For details about calibrating the balance (see chapter 3.8 "Weight calibration").

## 4.4.6 Temperature calibration

• TEMP. CAL.		
TEMP. CAL.	ON/OFF	<i>Activate the temperature calibration</i>

In order to calibrate the temperature (see chapter 7.3.2 "Calibrating the temperature")

## 4.4.7 Interface functions

• SET INTERFACE		
	BAUDRATE 300 BAUDRATE <b>600</b> BAUDRATE 1200 BAUDRATE 2400 BAUDRATE 4800 BAUDRATE 9600 BAUDRATE 19200	<i>Select the baud rate</i>
	PARITY <b>7-EVEN-1STOP</b> PARITY 7-ODD-1STOP PARITY 7-NO-2STOP PARITY 8-NO-1STOP	<i>Select the parity</i>
	HANDSHAKE <b>NO</b> HANDSHAKE XON-XOFF HANDSHAKE HARDWARE	<i>Select the handshake function</i>

The RS232/V24 interface on the instrument is matched to the interface of a peripheral instrument with the aid of the interface functions see chapter 6 "Data transfer")

## 4.4.8 Date and time

• SET DATE AND TIME		
	DATE [DD.MM.YY] TIME [HH.MM.SS] FORMAT <b>STANDARD/US</b>	<i>Set date and time</i>

### NOTE

If a power failure occurs, the timer keeps running. If this doesn't happen, this indicates that the instrument's backup battery has run out and has to be replaced by KERN Customer Service.

## 4.4.9 Password protection

The two main menus and the drying parameters for the MRS 120-3 can be protected against unwanted changes by using a freely selectable, four-digit password.

- If the password protection is deactivated, any operator can change the instrument settings.
- If “medium” password protection is activated, the configuration menu is protected against unwanted changes.
- If “high” password protection is activated, the configuration menu, the application menu and the drying parameters are protected.
- The disabled menu options and parameters can only be changed again by deactivating the password protection, i.e. by entering the correct password.

### NOTE

**The password protection is deactivated in the factory settings.**  
 The **preprogrammed password** set in the factory is: **7 9 1 4**  
 This password is the same for all KERN instruments and is always valid, at the same time as a password selected by the operator.  
 Keep a record of your **own password**.

• PASS-WORD		
PASSWORD	DATA-PROTECTION OFF	<i>No protection</i>
	DATA-PROTECTION MED	<i>The configuration menu is protected</i>
	DATA-PROTECTION HIGH	<i>The configuration and application menus, as well as the drying parameters are protected</i>
	NEW PASSWORD _ _ _ _	<i>Enter a new password</i>

Procedure for activating the password protection:

PASSWORD \_ \_ \_ \_

PASSWORD 0 0 0 0











PASSWORD 6 0 0 0

PASSWORD 6 1 0 0

DATA-PROTECTION OFF

DATA-PROTECTION OFF

DATA-PROTECTION MED

- Activate the configuration menu
- Keep pressing «» until "PASSWORD----" appears.
- Press «». The first digit in the password "- - - -" starts flashing.
- Keep pressing «» until the first digit in the password is correct.
- Press «».
- The second digit in the password display starts flashing now.
- Keep pressing «» until the second digit in the password is correct.
- Repeat these steps for the other two digits.
- Once you have entered all four digits, press «».
- Press «».
- 
- The current data protection status, "DATA-PROTECTION OFF", "DATA-PROTECTION MED" OR "DATA-PROTECTION HIGH" is now displayed.
- Press «».
- The display flashes.
- Keep pressing «» to change the password status.
- Press «» to save the entry.

Procedure for changing the password:

DATA-PROTECTION MED

- Enter the password and press «».

- The current data protection status is now displayed.

- Press «».

new PASSWORD 6 1 0 0

- Enter the new password,

- (e.g. 6123, procedure as described above).

new PASSWORD 6 1 2 3

- Press «» to save the entry.

## 4.4.10 Anti-theft encoding

The instrument can be protected against theft by using a freely selectable, four-digit numerical code:

- If the anti-theft code is deactivated, the instrument can be switched on again and operated after a power cutoff without having to enter a code.
- If the anti-theft code is activated, the instrument asks for the code to be input after each power cutoff.
- If the code is entered incorrectly, the instrument is blocked.
- If the instrument is blocked, it must first be disconnected from the power supply, then reconnected and unblocked by entering the correct code.
- After seven consecutive incorrect entries, the display reads “NO ACCESS, CALL SERVICE”. In this case only a KERN service engineer can unblock the instrument again.

### NOTE

**The anti-theft encoding is deactivated in the factory settings.**

The **preprogrammed code** set in the factory is: **8 9 3 7**

This code is the same in all KERN instruments. Therefore, for security reasons enter your own code.

Keep your **own code** in a safe place.

<b>• THEFTCODE</b>		
THEFTCODE ———	THEFT-PROTECTION ON/OFF	<i>Switch encoding on/off</i>
	NEW CODE ———	<i>Enter a new code</i>

In order to activate the anti-theft encoding, follow the same steps described for password protection.

#### **4.4.11 Key tone**

<b>• KEY TONE</b>		
KEY TONE	<b>ON/OFF</b>	<i>Switch key tone on and off</i>

If the key tone is switched on, a short audio signal is sounded each time a key is pressed.

## 4.5 Application menu operation

This section explains the structure of the application menu and its functions.

The structure of the application menu is dynamic and can be defined in the configuration menu (see chapter 4.4.4 "Configuring the application menu")

If a menu option is disabled in the configuration menu, it is not contained in the current application menu.

- The menu option "**RECALL METHOD**" cannot be switched on/off, it is ever present in the application menu.

Main path	Definable functions
<b>RECALL METHOD</b>	<i>Load a saved method</i>
<b>STORE METHOD</b>	<i>Save a method</i>
<b>CLEAR METHOD</b>	<i>Delete a saved method</i>
<b>METHOD</b>	<i>Enter the name of a method</i>
<b>SET TARGET WEIGHT</b>	<i>Definition of starting weight help</i>
<b>UNIT</b>	<i>Selection of the drying unit</i>
<b>PRINT RATE</b>	<i>Enter the interval time for the print rate Only if „PRINT RATE“ is also set in printformat</i>
<b>STANDBY TEMP.</b>	<i>Definition of the standby temperature function</i>
<b>AUTOSTART</b>	<i>Definition of the autostart function</i>

Representation conventions:

- The settings programmed in the factory are depicted in **bold**.
- In order to aid clarity, the only part of the menu tree shown in each function description is the part which relates to the application in question.

Explanations on the menu functions are depicted in *italics*.

## 4.5.1 Activating the application menu

- Press «**MENU**» following the start-up process in order to get to the application menu.

## 4.5.2 Methods

The MRS 120-3 supports the saving of five different methods. One method comprises the settings for the drying program and the starting weight help.

The following data is saved for each method:

- Name of the method
- Drying program with:
  - Drying mode
  - Drying temperature
- Stop time
- Autostop
- Autostart setting
- Standby temperature
- Unit for the result
- Starting weight with:
- Nominal weight
  - Upper weight limit
  - Lower weight limit

If the dryer is in weighing mode and the current starting weight is lower than the minimum sample weight (< 0.2 g), the name of the method currently loaded is displayed in the info line.

If the entry "EDIT METHOD" is switched off in the configuration menu under "Set application menu" ( see chapter 4.4.4 "Configuring the application menu"), the menu options "STORE METHOD" and "CLEAR METHOD" are no longer active. Consequently, the methods saved are protected against changes or can only be processed with existing saved methods.

All the current methods and their settings can be printed by keeping the "PRINT" key pressed in until "PRINT APPLICATIONS" appears (see chapter 4.6.2 "The print key").

## 4.5.2.1 Saving a method

### • STORE METHOD



STORE METHOD

*Save a method*

---

Procedure for saving a method:

STORE METHOD



- Set the drying parameters and the starting weight for the required method and enter a name for the method.
- (see chapter 4.5.2 "Methods")
- Activate the application menu by pressing the «MENU» key briefly.
- Keep pressing «» until "STORE METHOD" appears.
- Press «».  
If the method can be saved, you exit the menu automatically, and the dryer switches back to weighing mode.

The method cannot be saved if the name has already been used for an existing method in the memory:

REPLACE METHOD yes

or

REPLACE METHOD no

- REPLACE METHOD YES/NO" appears.
- Using the «» key, select "YES" if you wish to replace the existing method or "NO" if you wish to enter a different name for the new method.
- Press «».  
The method is saved. The dryer switches to weighing mode.
- Press «».  
The name of the method must be changed.

Method TEST

- Enter the new name for the method using the «↑», «↓», «←» and «→» keys.
- Press «↵». The method is saved. The dryer switches to weighing mode.

If all 5 memory slots are occupied, you won't be able to save a new method. In other words, you will have to delete one of the old methods first.

### 4.5.2.2 Loading a method

• RECALL METHOD		
RECALL METHOD	ttt... ttt... ttt... ttt... ttt...	<i>Select a method Only the existing methods are displayed!</i>

Only methods currently saved are displayed in the menu. If no methods are saved, you cannot go to the "RECALL METHOD" menu.

If you press the «E» key, the selected method is loaded, and the dryer switches back to the weighing mode.

### 4.5.2.3 Deleting a method

• CLEAR METHOD		
CLEAR METHOD	ttt... ttt... ttt... ttt... ttt...	<i>Select a method Only the existing methods are displayed!</i>

Only methods currently saved are displayed in the menu. If no methods are saved, you cannot go to the "CLEAR METHOD" menu. If you press the «E» key, the selected method is deleted, and the dryer switches back to the weighing mode.

#### NOTE

A saving sequence can be cancelled at any time by pressing «esc».

## 4.5.2.4 Setting method name

• METHOD		
METHOD	ttt...	<i>Enter the name for the method</i>

## 4.5.3 Starting weight

• SET TARGET WEIGHT		
	WEIGHT CHECK ON/OFF	<i>Switch check on/off</i>
	NOMINAL 5.000 g	<i>Enter nominal weight</i>
	UPPER LIMIT 6.000 g	<i>Define upper limit</i>
	LOWER LIMIT 4.000 g	<i>Define lower limit</i>

With the aid of the «TARGET WEIGHT», you can weigh the sample exactly to check that it matches a defined reference value plus/minus permissible deviations.

"+", "-" and «→||←» are active in the display.

If «→||←» lights up, this indicates that the measurement lies within the defined tolerances, and the drying process can commence. If the sample weight lies outside the starting weight tolerance, the drying process cannot be activated. In this case the starting weight tolerances are displayed on the screen as an error message.

## 4.5.4 Units

• UNIT	
UNIT	100-0% 0-100%
	ATRO 100-999%
	ATRO 0-999%
	G/KG
	RESIDUAL WEIGHT
	WEIGHT LOSS
	BALANCE WEIGHT

The unit of the measurement results printed in the report can be selected in the «UNIT» menu option. The defined unit is also used to print out interim values. The unit of measurement for the printout can only be changed before, and not during, a measurement.

The unit selected is also used as the display unit, although it can also be adjusted during and after the measurement . (see chapter 4.6.3"The change key")

## Description/calculation of the units

Explanation of the variables used

- MW: Moist weight (weight value at the start of the measurement)
- DW: Dry weight (weight value at the end of the measurement)

Unit	Calculation
Dry mass in percent:	$100 - 0\% = \frac{DW}{MW} \cdot 100\%$
Moisture in percent:	$0 - 100\% = -\frac{MW-DW}{MW} \cdot 100\%$
ATRO dry mass:	ATRO 100 - 999% = $\frac{MW}{DW} \cdot 100\%$
ATRO moisture:	ATRO 0 - 999% = $-\frac{MW-DW}{DW} \cdot 100\%$
Residual weight in g / kg [‰]:	$g / kg = \frac{DW}{MW} \cdot 1000$
Residual weight in g:	RESIDUAL WEIGHT = DW
Moisture in g:	WEIGHTLOSS = MW - DW
Current balance weight in g:	BALANCEWEIGHT = NETWEIGHT

### Explanations for the ATRO units

The ATRO unit is required exclusively in the wood industry.

In practice, wood contains different amounts of water, which can change continuously. The water content affects the combustion performance of the wood and the heat value. The water evaporates during drying. When wood is stored in the open air, it reaches the so-called air-dried status (A.D.) of 15% to 20% water content. The moisture is completely removed from the wood by heating the wood to temperatures over 100°C. This condition is called absolutely dry (abs.dry).

The wood moisture (*ATRO*) is the amount of water contained in the wood, expressed in terms of the percentage of the mass of the water-free wood and is calculated from the difference between the fresh weight (*MW*) and the dry weight (*DW*).

## 4.5.5 Print rate

• PRINT RATE	
PRINT RATE	1.0 MIN

*Print rate interval*

The interval at which interim results are printed is set at "PRINT RATE". The print interval can be set in 0.1 min increments from 0.1 ... 10.0 min.

## 4.5.6 Standby temperature

• STANDBY TEMP.	
STANDBY TEMP.	ON/OFF
TEMPERATURE	40°C

*Switch standby temperature on/off*

*Temperature value, only if the standby temperature is switched on*

Adjusts the temperature in the sample chamber to the set temperature, provided the sample chamber is closed. The temperature range available is 30°C ... 100°C. A flashing circle in the display indicates the standby temperature is not reached, yet.

## 4.5.7 Autostart

• AUTOSTART	
AUTOSTART	ON/OFF

If autostart is switched on, the measurement is started as soon as the sample chamber is closed. This is provided that the moisture analyzer is prepared for a new measurement.

## 4.6 Special operating keys

### 4.6.1 The tare key

- Ensure that there is no drying taking place, i.e. that the instrument is in weighing mode.
- **Activating taring**
  - Press «TARE» briefly.
  - A taring procedure is performed.
- **Activating calibration**
  - Keep «TARE» pressed until "BALANCE CALIBRATION" is displayed.
  - Release «TARE».
  - The balance carries out a calibration in accordance with the settings in the configuration menu and logs these in the form of a printout (see chapter 4.4.5 "Balance calibration" and chapter 7.3.1 "Calibrating the balance")
- **Activating a calibration test**
  - Keep «TARE» pressed until "TEST CALIBRATION" is displayed.
  - Release «TARE».
  - A calibration test is performed on the balance.
- **Activating a temperature calibration**
  - Keep «TARE» pressed until "TEMP. CALIBRATION" is displayed.
  - Release «TARE».
  - The MRS 120-3 moisture analyzer carries out a temperature calibration and logs it in the form of a printout (see chapter 4.4.6 "Balance calibration" and chapter 7.3.2 "Calibrating the balance").
- **Activating a temperature calibration test**
  - Keep «TARE» pressed until "TEST TEMPERATURE" is displayed.
  - Release «TARE».
  - The MRS 120-3 moisture analyzer carries out a temperature test.

## NOTE

The special functions of the tare key are only active if they are switched on in the configuration menu.  
A calibration or a calibration test procedure can be interrupted by pressing «ON/OFF». This applies both to the balance and to the temperature.

### 4.6.2 The print key

- Ensure that there is no drying taking place, i.e. that the instrument is in weighing mode.
- **Printing out an individual value or a report**
  - Press «**PRINT**» briefly.
  - The drying report is printed out. The report for the last measurement can be printed out at the start of a new drying procedure. Reports printed afterwards do not contain any interim results. It is otherwise identical to the drying report which is printed during the measurement. If no drying has been performed since the instrument was started up, the weight value is printed.
- **Resetting the counter to 1**
  - Keep «**PRINT**» pressed until "RESET COUNTER" is displayed.
  - Release «**PRINT**».
  - The counter is reset to 1.
- **Printing the instrument settings**
  - Keep «**PRINT**» pressed until "PRINT STATUS" is displayed.
  - Release «**PRINT**». The instrument settings are printed.

Status : -----	<i>Status printout for the settings.</i>
Date 07.10.2002 Time 16:12:39 Name : MRS 120-3 Software : N50-0040 P00 Serialno : 3300-1	<i>Instrument identification</i>
Print : Printformat : Date and Time : on Balance-ID : on Method-ID : on Counter : on Dryer Setup : on Print rate : off Operator-ID : off Print rate : 1.0 min Operator : Mode : Printer	<i>Report printout settings</i>
Calibration : Mode : external Defined weight : 0.0000 g	<i>Balance calibration settings</i>
Temp. cal. : off	<i>Temperature calibration settings</i>
Interface : Baudrate : 9600 Parity : 7-even-1stop Handshake : Hardware	<i>Interface settings</i>
Data-protection : off Theft-protection : off	<i>Security settings</i>
Key tone: on	<i>Key settings</i>



- **Printing the application settings**

- Keep «**PRINT**» pressed until "PRINT APPLICATIONS" is displayed.
- Release «**PRINT**».
- The application settings and all the settings for the methods currently saved are printed.

<p>Applications : -----</p>	<p><i>Printout of the application settings and methods.</i></p>
<p>Dryer setup : Heat mode : Standard Temperature : 105 C Timer stop : off Time : 10.0 min Auto stop : 2/20 D/s Free : 1/20 D/s Autostart : off Standby Temp : off Temperature : 40 C Unit : 100-0%</p>	<p><i>Current drying parameter settings</i></p>
<p>Targe weight : Weight check : off Nominal : 5.000 g Upper limit : 6.000 g Lower limit : 4.000 g</p>	<p><i>Current starting weight settings</i></p>
<p>Method : TEST Soft Dryer setup : Heat mode : Soft Temperature : 100 C Timer stop : on Time : 25.0 min Auto stop : off Free : 1/20 D/s Autostart: off Standby Temp : on Temperature : 40 C Unit : 100-0%</p> <p>Weight check : off Nominal : 6.000 g Upper limit : 7.000 g Lower limit : 5.500 g</p>	<p><i>Settings for the first method</i></p>
<p>Method : TEST Boost Dryer setup : Heat mode : Boost Temperature : 140 C Timer stop : off Time : 10.0 min Auto stop : AdaptStop Free : 1/20 D/s Autostart: :off Standby Temp : off Temperature : 40 C Unit : 100-0%</p> <p>Weight check : off Nominal : 3.500 g Upper limit : 4.000 g Lower limit : 2.500 g</p>	<p><i>Settings for the second method (all the methods saved are printed)</i></p>
<p>etc....</p>	<p><i>If methods three to five exist, they are also printed.</i></p>

### 4.6.3 The change key

- **Changing units**

- If drying has already been performed or is under way, the unit of measurement displayed can be changed using the change key «  ». Once a drying procedure is ended, the drying result can be displayed in all the available units until the start of a new drying sequence using the change key «  ».
- Release «  » once the unit to which you wish to change is displayed.

### 4.6.4 The start/stop key

- **Starting drying manually**

- Ensure that there is no drying taking place, i.e. that the instrument is in weighing mode.
- Press «**START/STOP**» briefly.
- The measurement is started.

- **Stopping drying manually**

- Drying is under way.
- Press «**START/STOP**» briefly.
- The measurement is stopped.

## **5 Determining moisture levels**

The MRS 120-3 moisture analyzer is used as a quick and reliable means of determining the moisture content in powders and liquids by the thermogravimetric process.

### **5.1 *Fundamental principles***

The term moisture does not just relate to water, it also encompasses all substances which evaporate when they are heated. Alongside water, they also include

- fats
- oils
- alcohol
- solvents
- etc...

There are different techniques for determining the moisture of a material.

Thermogravimetry is the technique used in the MRS 120-3. In this technique, the sample is weighed before and after heating so as to determine the moisture content from the difference.

The conventional drying oven technique works on the same principle except that, the measurement takes much longer. In the drying oven technique, the sample is heated from the outside inwards by a stream of hot air so as to draw out the moisture.

In the case of the halogen radiation used in the MRS 120-3, the radiation mainly penetrates into the sample where it is converted into heat energy, heating the sample from the inside out. A small portion of the halogen radiation is reflected by the sample; this reflection is lower in dark samples than in light samples. The penetration depth of the halogen radiation depends on the permeability of the sample. In the case of low-permeability samples, the halogen radiation only penetrates into the upper layers of the sample, which may lead to incomplete drying, charring or combustion. Consequently, the sample preparation is extremely important.

### 5.1.1 Adjusting to the existing measuring process

The MRS 120-3 moisture analyzer is frequently used in place of other drying techniques (like the drying oven) because it is easier to operate and offers shorter measuring times. Consequently, the conventional measuring process has to be adapted to the MRS 120-3 so that comparable results can be achieved.

- Performing a parallel measurement  
Lower temperature setting in the MRS 120-3 than in the drying oven technique
- The result achieved with the MRS 120-3 does not match the reference
  - Repeat the measurement with a changed temperature setting
  - Vary the switch-off criterion
- Adapting with the calibration curve or factor

## 5.2 Sample preparation

Prepare one sample at a time for measurement. This prevents the sample exchanging moisture with the ambient surroundings. If a number of samples have to be taken simultaneously, they should be packed in air-tight containers so as to ensure that they do not change while they are in storage.

Distribute the sample **evenly** and **thinly** on the weighing pan in order to achieve reproducible results.

If it is applied unevenly, this causes an inhomogeneous distribution of heat in the sample being dried, resulting in incomplete drying or an extension to the measuring time. If the sample is piled up, it heats up with greater intensity in the upper layers, causing combustion or encrustation to occur. The high layer thickness or possible formation of a crust prevents the moisture from escaping from the sample. This residual moisture means that measurement results achieved this way are not verifiable and reproducible.

#### Solids:



- Distribute powder samples evenly on the weighing pan.
- Make coarse samples smaller using a mortar or grinder. Do not expose the sample to any heat while you are grinding it as this will lead to a loss of moisture.

## Liquids:

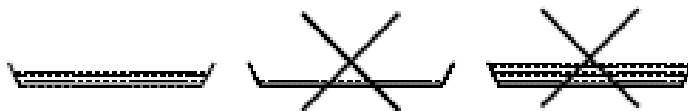

- You are advised to use a fiber glass filter for liquids, pastes or slurry samples. The fiber glass filter offers the following advantages:
  - even distribution on account of the capillary effect
  - no formation of drops
  - quick evaporation due to the larger surface

### 5.2.1 Preventing samples being encrusted

In order to avoid the sample becoming encrusted, solvent can also be added to the sample after the measurement has started. The solvent added has no bearing on the final result of the measurement.

- Start the measurement, automatically or by pressing the «**START/STOP**» key.
- The dryer hood can be opened again within 5 seconds of the start. During this time, the words "START DRYING" are displayed in the info line of the display.
- After opening the sample chamber, you can add additional solvent at any time until the hood is closed. Once the dryer hood is closed, the measurement is continued. "START COVER CLOSE" appears in the info line in the display. If you press the «**START/STOP**» key, the measurement is interrupted.

#### NOTE

The additional solvent is taken into account in the measurement printout because all the interim values are calculated on the basis of the current weight value.  
However, it has no bearing on the drying result because the solvent has completely dried off.

## 5.3 Setting drying parameters

The drying parameter setting procedure is started with the four function keys under the display.



Each of the four function keys starts the entry of the corresponding drying parameter. The parameters are entered or changed in the same way as the menu operation procedure ( except that only the current parameter can be changed each time.

### 5.3.1 Heating program

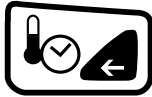

This function key is used to start the heating program selection. There are three heating programs available for determining the moisture content:

- Standard drying
- Boost drying (0.1Min – 99.9Min)
- Soft drying

• HEATING PROGRAM	
HEAT MODE	<b>STANDARD</b> BOOST SOFT

*Select the heating program  
BOOST-time selectable\**

\* The BOOST-Time can be set in 0.1 min increments from 0.1 min ... 99.9 min.

#### Standard drying

The drying temperature is predefined by the user. The end temperature is started up with a high heat output and is kept constant with slight overshooting.

This program is used for most samples.

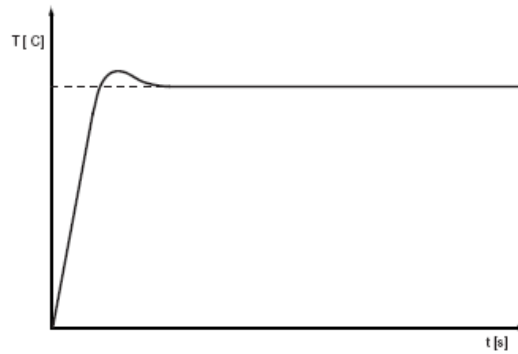

### Boost drying

The drying temperature is predefined by the user. During the selected time (0.1Min-99.9Min) of drying, the target temperature is exceeded by 40%. Once this time has elapsed, the temperature is adjusted down to the target temperature. The temperature is started up with a high heat output.

The maximum temperature reached during the boost is 230°C. This program is used for samples with a very high moisture content.

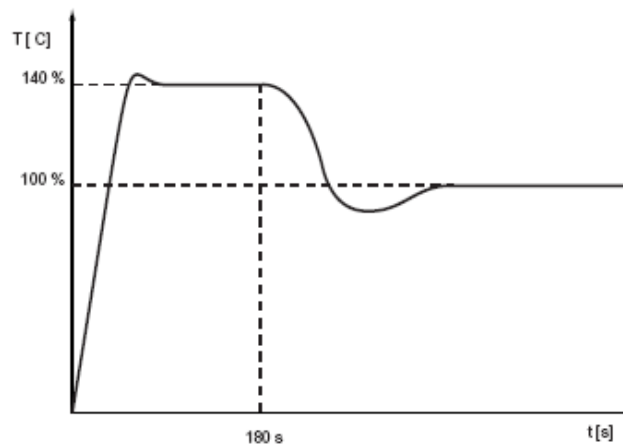

### Soft drying

The drying temperature is predefined by the user. The end temperature is started up gently with a low heat output. The end temperature is reached after approx. 4 minutes.

This program is used for samples with a low moisture content in which there is a risk of combustion.

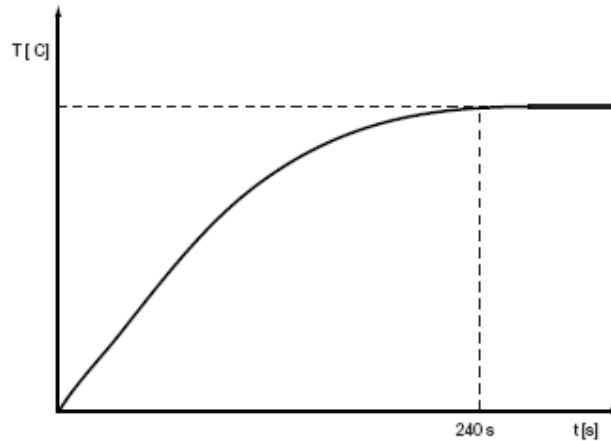

### 5.3.2 Temperature

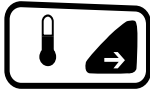

This function key is used to start the drying temperature input. The drying temperature can be entered in 1°C increments from 30°C ... 230°C. After 10 minutes temperatures higher than 200°C are automatically adjusted down to 200°C over the course of the next 20 minutes.

• DRYING TEMPERATURE		
TEMPERATURE	105°C	<i>Temperature input</i>

The temperature setting for drying with the MRS 120-3 is lower than in the case of drying with the drying oven technique.

### 5.3.3 Timer stop



This function key is used to define the drying time. If the timer stop is switched on, the measurement procedure is ended once the time set has elapsed. The time can be set in 0.1 min increments from 0.1 min ... 240.0 min.

• DRYING TIME		
STOP TIME	10.0 MIN	<i>Only if the timer stop is switched on</i>
TIMER STOP	ON/OFF	

### 5.3.4 Switch-off criteria



This function key is used to start the definition of the switch-off criteria for the measurement.

One firmly and 2 freely definable stop mode are available.

There is also the automatic stop mode "ADAPTSTOP".

- Digit / Time (selectable)
- Prozent / Time (selectable)
- ADAPTSTOP

• STOPMODE	
AUTOSTOP	OFF
	Digit / Time
	Percent / Time
	ADAPTSTOP

#### Switch-off criterion Digit per time

The drying procedure is switched off as soon as the reduction in weight, during the time set, is smaller than the number of digits set. The reduction in weight must have been greater than the switch-off criterion at some point.

In the freely definable mode, the user can set from 1 ... 99 digits in 1 digit increments and from 10...90 seconds in 10 second increments.

#### Switch-off criterion percent per time

The drying procedure is switched off as soon as the reduction in weight, during the percent set, is smaller than the number of digits set. The reduction in weight must have been greater than the switch-off criterion at some point.

In the freely definable mode, the user can set from 1 ... 99 digits in 1 digit increments and from 10...90 seconds in 10 second increments.

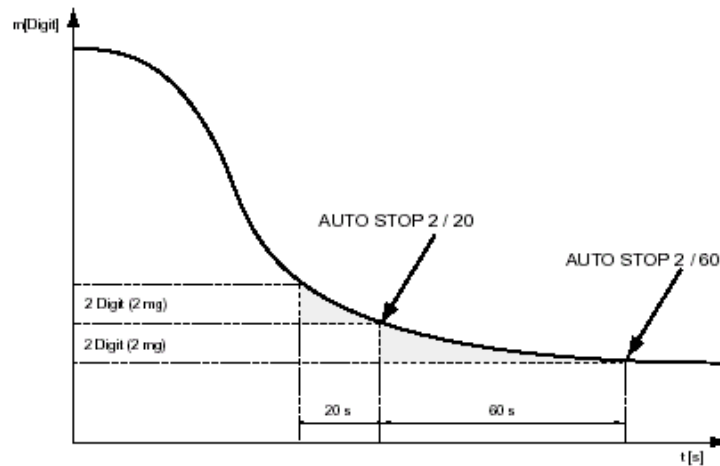

One digit is the smallest change in measurement that can be displayed by the moisture analyzer.

In the MRS 120-3: 1 digit = 1 mg

### **ADAPTSTOP**

Is a fully automatic stop mode which determines the switch-off time on the basis of the drying progress.

## **5.4 Application table (recommendations)**

### **Preparation of the standard sample:**

- Distribute the sample evenly on the aluminium tray.
- Reduce the sample to small pieces and distribute evenly on the aluminium tray.

### **Preparation of special samples:**

- A glass fibre filter can be used if the test material is sensitive or difficult to distribute (e.g. mercury).
- Apply the sample evenly to the glass fibre filter and cover with a second glass fibre filter.
- The glass fibre filter can also be used for protection against material splashes (every splash adulterates the final result).

<b>MATERIAL</b>	<b>Weight of test item (g)</b>	<b>Drying temperature (°C)</b>	<b>% humidity or % solid body</b>	<b>Standard divergence</b>	<b>Drying time (min)</b>
<b>Dry piece of apple</b>	5-8	100	76.5	0.1	10-15
<b>Moist apple</b>	5-8	100	7.5		5-10
<b>Butter</b>	2-5	138	16.3	0.1	4.5
<b>Mustard</b>	2-3	130	76.4	0.7	10
<b>Ground coffee</b>	2-3	106	2.8	0.1	4
<b>Cornflakes</b>	2-4	120	9.7		5-7
<b>Yogurt</b>	2-3	110	86.5		4.5-6.5
<b>Powdered coffee cream</b>	2-3	130	78.5	0.1	6-8
<b>Cocoa powder</b>	2-3	106	0.1	0.1	2
<b>Crisps</b>	3-4	106	6.9	0.1	7.5
<b>Margarine</b>	3-4	138	16	0.1	10
<b>Mayonnaise</b>	1-2	138	56.5	0.4	10
<b>Powdered milk</b>	2-4	90	5	0.2	6
<b>Milk chocolate</b>	2-5	106	1.3	0.1	3.5
<b>Red wine</b>	3-5	100	97.4	0.1	15-20
<b>Chocolate powder</b>	2-4	100	1.9	0.1	4
<b>Sunflower oil</b>	10-14	138	0.1		2
<b>Instant soup powder</b>	2-3	80	3	0.2	4.5-7
<b>Sugar</b>	4-5	138	11.9	0.1	10
<b>Milk</b>	2-3	120	88	0.2	6-8
<b>Flour</b>	8-10	130	12.5	0.1	4-5
<b>Cement</b>	8-12	138	0.8	0.1	4-5
<b>Paper</b>	2-4	106	6.4	0.1	10
<b>Sludge</b>	11-12	130	80		90
<b>Polyamide</b>	2-5	138	2	0.2	75
<b>Dust</b>	5-10	104	7.3	0.3	8-15
<b>Charcoal</b>	8-10	120	3.8	0.1	8-10

## 6 Data transfer

The MRS 120-3 moisture analyzer is equipped with an RS232/V24 interface for data transfers to peripheral instruments.

Before the data transfer, the RS232 interface must be matched with the one in the peripheral instrument in the instrument's configuration menu

(see chapter 4.4.7"Interface functions").

- Handshake

The handshake is set in the factory to "NO". It can be set to software handshake XON/XOFF or to hardware handshake.

- Baud rate

Possible baud rates: 300, 600, 1200, 2400, 4800, 9600 or 19200 baud.

- Parity

Possible parity: 7-even-1 stop, 7-odd-1 stop, 7-no-2 stop or 8-no-1 stop.

$\pm 12 V$	<b>SB</b>	<b>1</b>	<b>2</b>	<b>3</b>	<b>4</b>	<b>5</b>	<b>6</b>	<b>7</b>	<b>8</b>	<b>SP</b>
7-even-1	SB	1. DA	2. DA	3. DA	4. DA	5. DA	6. DA	7. DA	PB	SP
7-odd-1	SB	1. DA	2. DA	3. DA	4. DA	5. DA	6. DA	7. DA	PB	SP
7-no-2	SB	1. DA	2. DA	3. DA	4. DA	5. DA	6. DA	7. DA	1. SP	2. SP
8-no-1	SB	1. DA	2. DA	3. DA	4. DA	5. DA	6. DA	7. DA	8. DA	SP

SB: Start bit                      PB: Parity bit

DA: Data bit                      SP: Stop bit

– Display

S	D7	D6	D5	D4	D3	D2	D1	D0	U	U	U
---	----	----	----	----	----	----	----	----	---	---	---

–

Data transfer takes place in ASCII code:

1	2	3	4	5	6	7	8	9	10	11	12	13	14	15	...	...	...
<b>B</b>	<b>B</b>	<b>B</b>	<b>S</b>	<b>D7</b>	<b>D6</b>	<b>D5</b>	<b>D4</b>	<b>D3</b>	<b>D2</b>	<b>D1</b>	<b>DP</b>	<b>D0</b>	<b>B</b>	<b>U</b>	...	<b>CR</b>	<b>LF</b>

B	Blank (space)
S	Prefix (+,-, space)
DP	Decimal point
D0...D7	Digits
U ...	Unit (only if the weight is stable, otherwise no unit is sent)
CR	Carriage return
LF	Line feed

NOTE
Unused positions are filled with spaces. The decimal point DP can be between D0 and D7.

## 6.1 Connection scheme

– Standard duplex connection

MRS 120-3	RJ 45	D25 / D9	Peripheral instrument
RS 232 out	2	→ 3 / 2	RS 232 in
RS 232 in	6	← 2 / 3	RS 232 out
GND	5	— 7 / 5	GND

- Standard duplex connection with additional hardware handshake in the peripheral instrument

MRS 120-3	RJ 45	D25 / D9	Peripheral instrument
RS 232 out	2	→ 3 / 2	RS 232 in
RS 232 in	6	← 2 / 3	RS 232 out
GND	5	— 7 / 5	GND
CTS	3	← 20 / 4	DTR
DTR	7	→ 5 / 8	CTS

- Pin configuration of the RJ45 socket

MRS 120-3	RJ 45	Remark
n.c.	1	Not connected
RS 232 out	2	Out (V24)
CTS	3	In (V24)
VDC	4	Out (9 ... 16V)
GND	5	0V
RS 232 in	6	In (V24)
DTR	7	Out (V24)
EXTBUS	8	In (5V, logic)

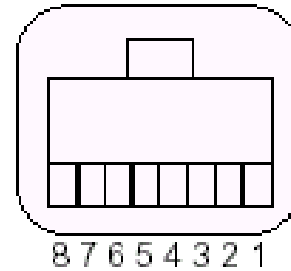

## 6.2 Remote control commands

Command	Function
ACKn	Acknowledge n=0 off; n= 1 on
CAL	Start calibration (only if EXT is selected)
DN	Reset weight display
D .....	Describe weight display (right-aligned)
@N	Reset info display
@ .....	Describe info display
N	Reset instrument
OFF	Switch off instrument
ON	Switch on instrument
PCxxxx	Enter anti-theft code
PDT	Print date and time
PRT	Start printing (Press « <b>PRINT</b> » key)
PST	Start print status
Pn (ttt.t)	Set print mode n = 0 Individually print each valu (unstable) n = 1 Individually print a stable value (stable) n = 2 Print after change of load n = 3 Print after each integration period n = 4 Print with time basis in s (ttt.t)
SDTttmmjj hhmmss	Set date and time (German: Tag, Monat, Jahr, Stunde, Minute, Sekunde)

Command	Function
SDTmmddy hhmmss	Set date and time (Month, Day, Year, Hour, Minutes, Seconds)
T (ttt)	Tare or set tare to a specific value
ZERO	Set instrument to 0 (if weight is stable and within the zero setting range)
Rttt	Adjusts the heating to the required temperature (30°C ... 230°C)
ROFF	Switch off heating
PWT (ttt.t)	Print weight value and temperature value Print with time basis in s (ttt.t) (switch off by transmitting PWT)

### NOTE

Each remote control command must terminate with «CR» «LF».  
The commands are acknowledged if required.

## 6.2.1 Examples of the remote control of the instr.

Input	Description of the function activated
D - - - - -	Five dashes are displayed
DTEST123	tEST123 is displayed
D	The display is dark
T10	-10.000 g (Tare set to = 10 g)
T1	-1.000 g (Tare set to = 1g)
T	Instrument is tared
R100	Adjusts the temperature to 100 °C

## 7 Service

### 7.1 *Maintenance and servicing*

The MRS 120-3 moisture analyzer must be treated carefully and cleaned regularly. This is a precision instrument

#### **DANGER**

To facilitate maintenance work, the instrument must be disconnected from the power supply. Also ensure that the instrument cannot be reconnected to the power supply during the work by anyone else. Take care during cleaning that no liquid gets into the instrument. If you spill any liquid onto the instrument, unplug it from the electrical supply immediately. Do not operate the MRS 120-3 moisture analyzer again until you have had it checked by a KERN service engineer.

The connection ports on the back of the instrument may not come into contact with liquids.

Regularly dismantle the weighing pan and the weighing pan holder and remove any dirt or dust from under the weighing pan and on the balance housing with a soft brush or a soft, lint-free cloth, moistened with a mild soap solution.

The balance pan and the holder can be cleaned under running water. Take care to ensure that both parts are completely dry before they are re-installed on the balance.

#### **CAUTION**

Never use solvents, acids, alkalis, paint thinners, scouring powders or other aggressive or corrosive chemicals for cleaning since these substances attack the surfaces of the instrument housing and can cause damage.

Regular maintenance of the MRS 120-3 moisture analyzer by your KERN service agent will guarantee unrestricted functioning and reliability over many years and will extend the lifespan of the instrument.

## 7.2 Replacing the mains fuse

If the display remains dark after you switch on the instrument, this generally means that the instrument's fuse is faulty and has to be changed.

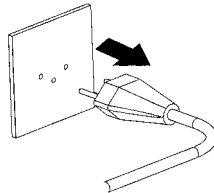

### **DANGER**

**Unplug the instrument from the mains before replacing the fuses.**

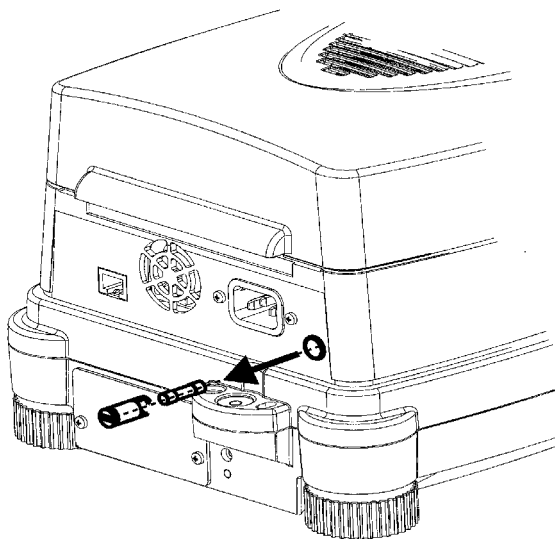

Screw open the fuse holder on the back of the instrument using a screwdriver, screwing anticlockwise.

Replace the faulty fuse:

230 volt variant:

**T 3.15 A, 230 V, 5x20 mm**

115 volt variant:

**T 6.3 A, 115 V, 5x20 mm**

If the instrument still does not work after replacing the fuse, contact the KERN Service Center.

### **DANGER**

**Under no circumstances should you use other fuses or attempt to bridge the fuse.**

## 7.3 Calibration

The calibration of the MRS 120-3 moisture analyzer is defined in the configuration menu (see chapter 3.8 "Weight calibration" and chapter 4.4.5 "Balance calibration").

### NOTE

The balance calibration and the temperature calibration can be interrupted at any time by pressing «**ON/OFF**».

### 7.3.1 Calibrating the balance

Possible types of balance calibration:

- External calibration by means of ICM (Intelligent Calibration Mode)
- External calibration with a freely definable weight

#### External calibration by means of ICM

Calibration weights in increments of 10g can be used for the MRS 120-3 moisture analyzer whereby the calibration weights must correspond to the precision of the instrument.

"SET CALIBRATION MODE EXTERNAL" must be set in the configuration menu (see chapter 4.4.5 "Balance calibration") for external calibration by means of ICM.

Balance calibration

-- 0000 9

-- 50 9

- Ensure that there is no drying taking place, i.e. that the instrument is in weighing mode.
- Keep pressing «**TARE**» until
- "BALANCE CALIBRATION" is displayed.
- The instrument performs a zero point measure (0000 g is displayed flashing).
- After the zero point measurement, the display flashes the recommended calibration weight.
- Put the calibration weight on.

-- 50 9

+ 50 9

- The display flashes.
- Once the display stops flashing, this indicates that the calibration has ended.

### External calibration with a freely definable weight

"SET CALIBRATION MODE EXT.-DEF." must be set in the configuration menu (see chapter 4.4.5 "Balance calibration") for external calibration with a freely definable weight.

You then need to enter the effective value of the calibration weight (DEF. n,nnnn g) with up to ten times the precision of the instrument balance.

#### NOTE

Is calibrated with the free weight, so only this weight may be used.

Procedure to follow:

Balance calibration

-- 0000 9

-- 22 9

-- 22 9

+ 22.150 9

- Ensure that there is no drying taking place, i.e. that the instrument is in weighing mode.
- Keep pressing «**TARE**» until
- "BALANCE CALIBRATION" is displayed.
- The instrument performs a zero point measure (0000 g is displayed flashing).
- After the zero point measurement the display flashes the calibration weight entered beforehand.
- Put the calibration weight on.
- The display flashes.
- Once the display stops flashing, this indicates that the calibration has ended (the precise value is displayed).

## Calibration report printout

Calibration -----	Balance calibration report
Date 16.10.2003 Time 12:51:36 Name : MRS 120-3 Software : N50-0000 P00 Serialno : 3300-1	Time of the calibration and instrument data
Calibration o.k.	Status of the calibration
Operator :	Operator ID, if activated under Set Print Format (see chapter 4.4.3 Configuring the report printout”).

### 7.3.2 Calibrating the temperature

In order to enable a temperature calibration to take place, "TEMP. CAL." must be switched on in the configuration menu (see chapter 4.4.6 "Temperature calibration").

The temperature adjustment set must be connected to the moisture analyzer via the RS232 interface, and the temperature sensor must be inserted in the sample chamber.

Procedure to follow:

temp. CALIBRation

Press SArt-KEY

TEMP 25°C 40.00 MIN

- Ensure that there is no drying taking place, i.e. that the instrument is in weighing mode.
- Keep pressing «**TARE**» until
- "TEMP. CALIBRATION" is displayed.
- Once the temperature adjustment set is connected to the instrument, press «**START STOP**».
- The temperature calibration is started. The dryer heats up to 100°C. The temperature and the time remaining for the temperature calibration are displayed in the info line. It takes 20 minutes to heat up to a temperature.

TEMP 100°C

20.00 MIN

- The temperature value is transmitted to the instrument from the temperature adjustment set.
- It is heated to 160°C.
- The temperature value is transmitted to the instrument from the temperature adjustment set.
- Once the temperature calibration has ended, the report is printed.

### Temperature calibration report printout

Temperature Calibration -----	Temperature calibration report
Date 16.10.2003 Time 12:51:36 Name : MRS 120-3 Software : N50-0000 P00 Serialno : 3300-1	Time of the calibration and instrument data
Temp. Reference ID : ...	Identifier of the temperature adjustment set
Temperature 100 C : 100 C Temperature 160 C : 160 C	Status of the temperature calibration
Temperature Calibration o.k.	Instrument has been correctly temperature-calibrated
Operator :	Operator ID, if activated under Set Print Format (see chapter 4.4.3 Configuring the report printout).

## 7.4 Software update via Internet

Downloads with Software updates are available from the Internet .

<http://www.mrs.kern-sohn.de>

## 7.5 Error messages

The instrument displays an error description in the info line.

NOTE	
If an error occurs without any corresponding description in the info line, a KERN service engineer must be called.	
Error message	Cause
Starting value too small	<ul style="list-style-type: none"><li>The sample weight is too small (&lt;0.200 g). The sample weight must be greater than 0.200 g.</li></ul>
LOWER LIMIT x.xxx g UPPER LIMIT x.xxx g	<ul style="list-style-type: none"><li>The sample weight does not lie within the tolerance for the starting weight.</li></ul>

### 7.4.1 Notes on correcting faults

Faults and their possible causes should be listed in the following table. If you cannot clear the fault on the basis of the table, please contact a KERN service engineer.

Fault	Possible causes
Weight display does not light up	<ul style="list-style-type: none"><li>Instrument is not switched on</li><li>Mains cord is not plugged in</li><li>Mains fuse is faulty</li></ul>
"OL" is displayed	<ul style="list-style-type: none"><li>The weight range has been exceeded (observe the information on the maximum weight range)</li></ul>
"UL" is displayed	<ul style="list-style-type: none"><li>The weight range is below the range of the instrument (weighing pan or pan holder missing)</li></ul>

Fault	Possible causes
Results of weighing are clearly incorrect	<ul style="list-style-type: none"> <li>• The instrument has not been correctly tared</li> <li>• The instrument has not been correctly levelled</li> <li>• The calibration is no longer correct</li> <li>• Sharp temperature fluctuations occur</li> </ul>
The weight display changes continuously	<ul style="list-style-type: none"> <li>• The draft is too strong at the location of the instrument</li> <li>• The instrument support is vibrating or fluctuating</li> <li>• The weighing pan is touching a foreign body</li> <li>• The sample is absorbing moisture</li> <li>• The sample is evaporating/vaporising/subliming</li> <li>• Sharp changes in temperature in the sample</li> </ul>
Configuration menu cannot be changed	<ul style="list-style-type: none"> <li>• The password lock is activated in the configuration menu</li> </ul>
The display flashes continuously during calibration	<ul style="list-style-type: none"> <li>• The instrument location is not quiet enough (interrupt calibration with «<b>ON/OFF</b>» and move the balance to a better location).</li> <li>• Use of a calibration weight which is too imprecise (only applies to external calibration)</li> </ul>
The connected printer won't work	<ul style="list-style-type: none"> <li>• The printer is not switched on</li> <li>• The data cable is faulty or not connected</li> <li>• The interface settings do not match the moisture analyzer</li> </ul>
The printer prints incorrect characters	<ul style="list-style-type: none"> <li>• The parity setting or the baud rate of the interface don't match</li> <li>• The data cable is faulty</li> </ul>
Drying won't start	<ul style="list-style-type: none"> <li>• The sample is not stable</li> </ul>

## 8 Overview

### 8.1 *Technical data*

Heat source, heater type	Halogen
Weighing range [g] / Readability [g]	120 / 0.001
<b>Drying:</b>	
Readability [%]	0.01
Reproducibility in approx. 1g [%]	0.2
Reproducibility in approx. 10g [%]	0.02
Sample weight [g]	0.2 - 120
Result calculations:	100-0%, 0-100% ATRO 100-999%, ATRO 0-999%, G/KG, RESIDUAL, LOSS
<b>Heating:</b>	
Temperature range [°C] / Increment [°C]	30 - 230 / 1
Heating methods	Standard, Boost, Soft
Intervals	Boost + 1 (1-99)
Booster	+40% during selectable time
<b>Switch-off criteria:</b>	
Autostop [d/s]	4 fixed settings or freely definable 1 - 99 / 10 - 90
	<b>Digit / Time</b>
	<b>Percent / Time</b>
Timer stop [min.]	0.1 - 240.0
<b>Monitoring:</b>	
Viewing window	x
Audio	x
<b>Printout:</b>	
GLP	x
Printout - Interval [min.]	0.1 - 10.0
Sample numbering	x

Memory capacity:	
Methods (with all settings)	5
User texts	2
Operation:	
"Easy access" sample holder	x
Display	VFD
Keypad	10 keys
Password protection	x
Special features:	
Initial weighing with limits / Initial weighing help	x / x
Software download and update	x
Calibration:	
Balance	with a test weight
Temperature, fully automatic	at 100°C and 160°C
Miscellaneous:	
Timer for date and time	x
Interface for PCs and printers	RS232
KERNBus	x
Digital I/O	optional
Anti-theft protection	Code and mechanically
Connection:	
Mains voltage	230V or 115V Can be switched by changing the unit of heat (may only be done by KERN Service)
Mains frequency [Hz]	50 - 60
Power consumption [W]	450
Dimensions:	
Instrument housing (WxHxD) [mm]	210x170x340
Weight [kg]	6.3

## 8.2 Configuration menu tree

«MENU» Key is pressed during switch-on:

<b>• SET DATA PRINT</b>			
	SET PRINTFORMAT	DATE AND TIME	<b>ON/OFF</b>
		BALANCE-ID	<b>ON/OFF</b>
		METHOD-ID	<b>ON/OFF</b>
		COUNTER	<b>ON/OFF</b>
		DRYER SETUP	<b>ON/OFF</b>
		PRINT RATE	<b>ON/OFF</b>
		OPERATOR-ID	<b>ON/OFF</b>
		PRINT RATE	<b>1.0 MIN</b>
		OPERATOR	ttt...
	MODE	<b>PRINTER</b>	
	MODE	PC	
<b>• SET APP. MENU</b>			
	EDIT METHOD	<b>ON/OFF</b>	
	METHOD-ID	<b>ON/OFF</b>	
	TARGET WEIGHT	<b>ON/OFF</b>	
	UNIT	<b>ON/OFF</b>	
	PRINT RATE	<b>ON/OFF</b>	
	STANDBY TEMP.	<b>ON/OFF</b>	
	AUTOSTART	<b>ON/OFF</b>	
<b>• SET BALANCE CAL.</b>			
	MODE	OFF	
	MODE	<b>EXTERNAL</b>	
	MODE	EXT.-DEF.	
	DEF.	<b>0.0000 g</b>	
<b>• TEMP. CAL.</b>			
	TEMP. CAL.	<b>ON/OFF</b>	

• SET INTERFACE	
	BAUDRATE 300 BAUDRATE <b>600</b> BAUDRATE 1200 BAUDRATE 2400 BAUDRATE 4800 BAUDRATE 9600 BAUDRATE 19200
	PARITY <b>7-EVEN-1STOP</b> PARITY 7-ODD-1STOP PARITY 7-NO-2STOP PARITY 8-NO-1STOP
	HANDSHAKE <b>NO</b> HANDSHAKE XON-XOFF HANDSHAKE HARDWARE

• SET DATE AND TIME	
	DATE [DD.MM.YY]
	TIME [HH.MM.SS]
	FORMAT <b>STANDARD/US</b>

• PASSWORD	
PASSWORD —	DATA-PROTECTION <b>OFF</b> DATA-PROTECTION MED DATA-PROTECTION HIGH
	NEW PASSWORD - - - -

• THEFTCODE	
THEFTCODE —	THEFT-PROTECTION <b>OFF</b> THEFT-PROTECTION ON
	NEW CODE - - - -

• KEY TONE	
KEY TONE	<b>ON/OFF</b>

• CONTRAST	
CONTRAST	6

• LANGUAGE	
------------	--

	LANGUAGE	ENGLISH
	SPRACHE	DEUTSCH
	LANGUE	FRANCAISE

## 8.2.1 Application menu tree

«MENU» Key is pressed during operation:

• RECALL METHOD	
-----------------	--

RECALL METHOD	ttt... ttt... ttt... ttt... ttt...
---------------	--

• STORE METHOD	
----------------	--

STORE METHOD	
--------------	--

• CLEAR METHOD	
----------------	--

CLEAR METHOD	ttt... ttt... ttt... ttt... ttt...
--------------	--

• METHOD	
----------	--

METHOD	ttt...
--------	--------

• SET TARGET WEIGHT	
---------------------	--

	WEIGHT CHECK	ON/OFF
	NOMINAL	5.000 g
	UPPER LIMIT	6.000 g
	LOWER LIMIT	4.000 g

• UNIT

UNIT	<b>100-0%</b>
	0-100%
	ATRO 100-999%
	ATRO 0-999%
	G/KG
RESIDUAL WEIGHT	
WEIGHT LOSS	
BALANCE WEIGHT	

• PRINT RATE

PRINT RATE	<b>1.0 MIN</b>
------------	----------------

• STANDBY TEMP.

STANDBY TEMP.	<b>ON/OFF</b>
---------------	---------------

TEMPERATURE	<b>40°C</b>
-------------	-------------

• AUTOSTART

AUTOSTART	<b>ON/OFF</b>
-----------	---------------

## 8.2.2 Key menus



Hold the appropriate key down until the required menu option appears in the info line. The options „PRINT“ and „TARE“ are not displayed.

	• Print key	<i>not displayed</i>
	PRINT	
	RESET COUNTER	
	PRINT STATUS	
	PRINT APPLICATIONS	

	• Tare key	<i>not displayed</i>
	TARE	
	BALANCE CALIBRATION	
	TEST CALIBRATION	
	TEMP. CALIBRATION	
	TEST TEMPERATURE	

	• Change key
	100-0%
	0-100%
	ATRO 100-999%
	ATRO 0-999%
	G/KG
	RESIDUAL WEIGHT
	WEIGHT LOSS
	BALANCE WEIGHT

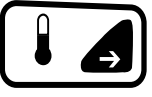
### 8.2.3 Setting drying parameters

	<p>• <b>HEATING PROGRAM</b></p> <p>HEAT MODE      <b>STANDARD</b>                                   BOOST                                   SOFT</p>
	<p>• <b>DRYING TEMPERATURE</b></p> <p>TEMPERATURE      <b>105°C</b></p>
	<p>• <b>DRYING Time</b></p> <p>STOP TIME      <b>10.0 MIN</b></p> <p>TIMER STOP      <b>ON/OFF</b></p>
	<p>• <b>STOPMODE</b></p> <p>AUTOSTOP      <b>OFF</b>                                   Digit / Time                                   Percent / Time                                   ADAPTSTOP</p>

### 8.2.4 Setting and saving the configuration

«MENU» and «TARE» keys are pressed during switch-on:

<p><b>FACTORY CONFIG.</b></p>	<p>Load the factory configuration</p>
<p><b>USER CONFIG.</b></p>	<p>Load the user configuration</p>
<p><b>STORE CONFIG.</b></p>	<p>Save the current user configuration</p>